

## ■ Dimensions

Unit:mm

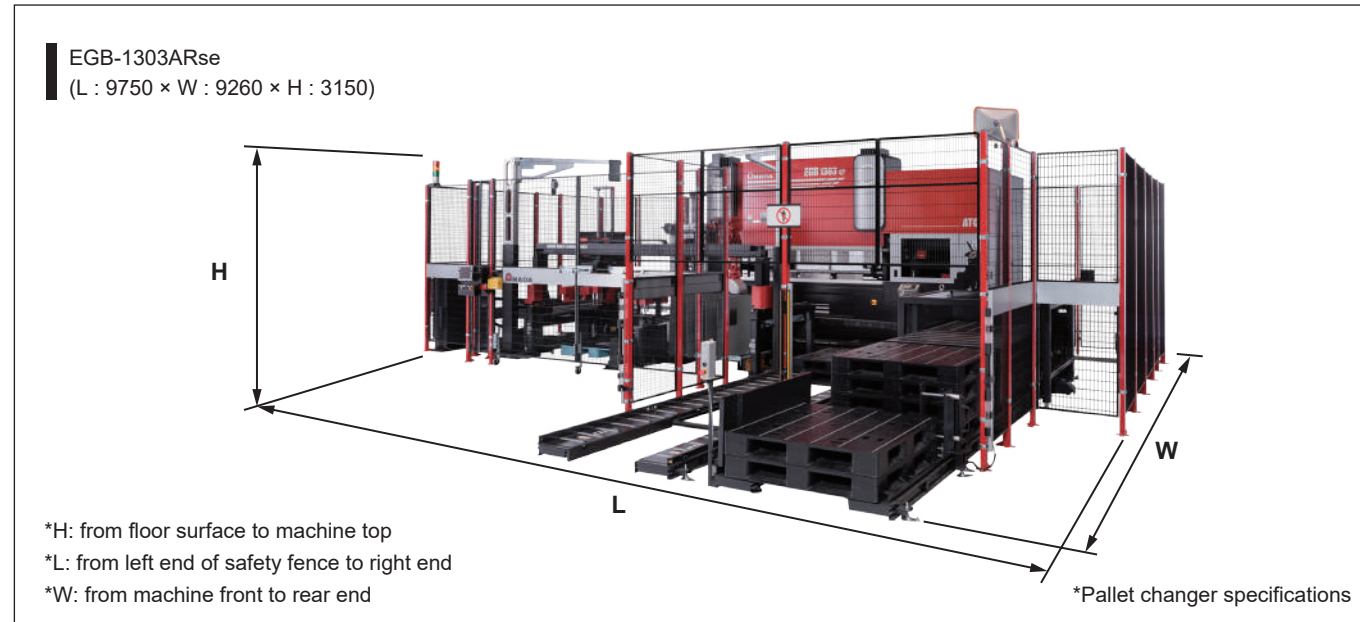

## ■ Machine Specifications

Model		EGB-1303ARse			
Press brake	Model name	EGB1303ARE			
	machine	Tonnage capacity	kN	1300	
		Open height	mm	620	
		Stroke length	mm	250	
		Approach speed	mm/s	250	
	Max. bending speed	mm/s	9(without robot-motion)		
ATC	No. of punch stocker	18			
	No. of die stocker	25			
Robot	Model name	EGBRBT020E			
	Axis composition	Robot : 6 axes Travel axis:1 axis			
	Payload	kg	20 (with gripper)		
	Max. workpiece size	mm	800 × 1000 or 500 × 1200		
	Min. workpiece size	mm	90 × 150		
	Workpiece thickness	mm	0.5 - 6.0		
	Traveling axis	Stroke	m	6.4	
		Combination type	set	6	
	No. of gripper	Vacuum type	set	3	
		Amada Smart loading device	Vacuum type	set	3
	Loading unit	No. of loading position	positions	2	
		Workpiece stacking height	mm	200(when LD camera is used)	

\*Specifications, appearances and equipment are subject to change without notice by reason of improvement.  
\*Official model names of machine & device described in this catalog is EGB6013ARse  
EGB6013ARse is the name of system combining EGB1303ARE and EGBRBT020E  
\*The hyphenated spellings EGB-1303ARse is used in some portion of this catalog for sake of readability.  
\*The specifications described in this catalog are for the Japanese domestic market

**Be sure to read the manual carefully before use.**  
• Use of this product requires safeguard measures to suit your work

© AMADA CO., LTD. All Rights Reserved.

**AMADA CO., LTD.**  
200, Ishida, Isehara-shi, Kanagawa, 259-1196, Japan  
www.amada.co.jp



E170-HQ01en  
Dec. 2023

General-purpose Automatic Bending System with Electric Servo Drive



# EGB 1303 ARs



Electric servo drive press brake  
designed for people and the environment.



**The Engineering AMADA**



## Smart operation

# Selectable peripheral devices lead to the future of bending automation

The EGB-1303ARse, featuring a new servo drive system, has transformed into an environmentally friendly high-end bending automation system. The AMADA Smart Loading Device, designed for user convenience, facilitates pallet operation without the necessity of re-stacking blanks. A range of unloading options is available, allowing customers to choose based on their operational preferences.

# 4i<sub>e</sub>



General-purpose Automatic Bending System with Electric Servo Drive

# EGB 1303 ARs

## Processing samples

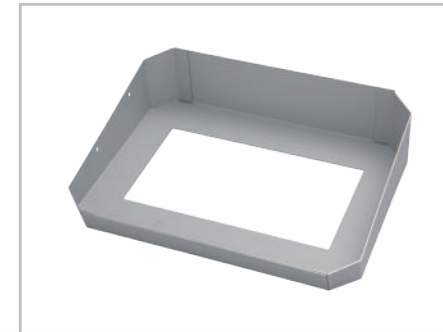

### Monitor box part

Material : SECC  
 Thickness : 1.0mm  
 Size : 245 x 187.6 x 59.8mm  
 No. of bend : 10 bends  
 Processing time : 3 min. 6 sec.

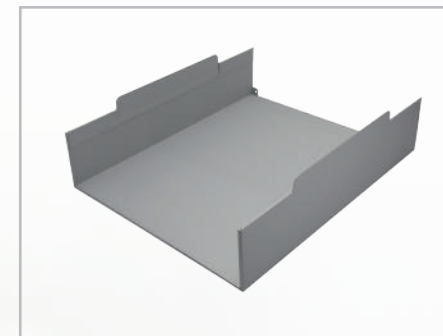

### Monitor box part

Material : SECC  
 Thickness : 1.0mm  
 Size : 360 x 446.2 x 122mm  
 No. of bend : 6 bends  
 Processing time : 3 min.



## AMNC 4i<sub>e</sub>



### AMADA's four new "e"s

Easy operation for anyone to use  
**Easy**

Efficiency in remote operation from anywhere  
**Efficiency**

Environmental sustainability in production  
**Environmental**

Evolution together with our customers  
**Evolution**



"4i" adds new elements to the conventional 3i

**Intelligent**  
**Interactive**  
**Integration**  
**Innovative**



# EGB-1303ARse Solution

## Press brake

Model name : EGB1303ARE



Capacity 1300kN  
Open height 620mm  
Stroke 250mm

## New servo drive

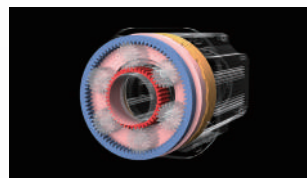

An environmentally friendly new type of servo drive has been adopted.

## Robot (Articulated robot with 6 axes)

Model name : EGBRBT020E



Payload 20kg (with gripper).  
An articulated 6-axes robot with a range similar to that of the human arm plus one traveling axis.

## L-shift back gauge + Side gauge

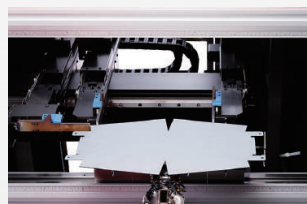

Back gauge system for diverse external shapes, ensuring stable gauging of tapered edges and tab bending.

## Processing range\*1

Unfold size  
90×150mm - 800×1000mm, 500×1200mm  
Thickness : 0.5 - 6.0mm

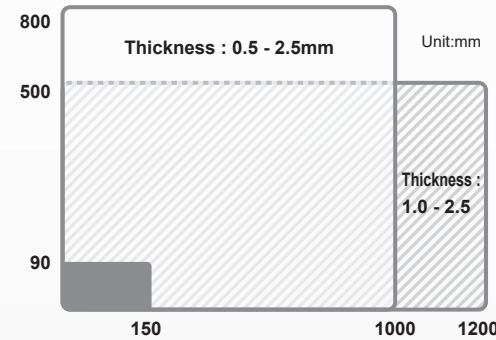

## AGC (Automatic Gripper Changer)

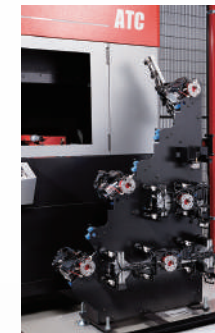

Grippers are automatically exchanged based on the products.  
It is possible to install grippers at up to 9 stations.

## AMADA smart loading device + LD camera

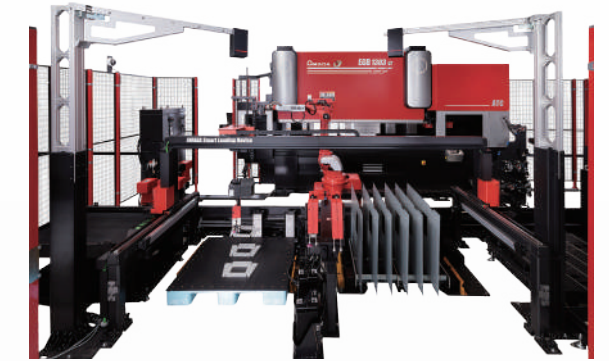

Independent device for increased efficiency in loading of parts blanks.  
The loading pallet eliminates dead space, maximizing loading capacity.

- Processing speed is increased
- Solution for single part pickup
- Support high-mix low-volume production

## Unloading Options



A selection of devices for unloading of parts after processing is available. Customers can choose a method according to their operation.

## ATC (Automatic Tool Changer)



Automatic tool change function for accelerated setup.  
Capacity is expanded to 18 punch units and 25 die units.

## Sensing function

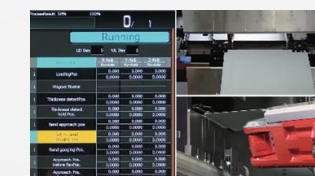

Numerous operator support functions, such as Bi-SII and Z-axis sensing, are incorporated.

\*If the blank mass exceeds the robot's payload capacity, processing may not be possible even if it falls within the specified range.



## Easy Easier for anyone

Option

### Automatic correction

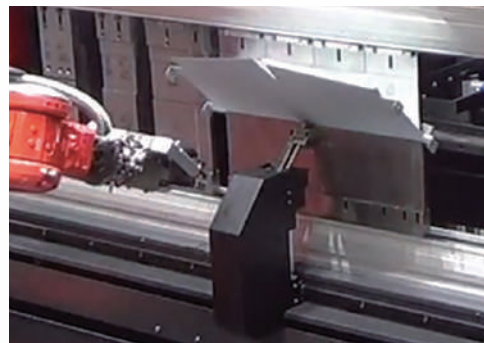

#### Contact-type angle sensor Bi-SII

Available tools V6 - V50 \*  
Angle range 90° - 165°  
Minimum flange : 16mm(V6) - 50mm(V50)  
No. of Bi unit Auto 2-axes

\* Shut height of V-50 is different from other V die sizes.

### Setup Support

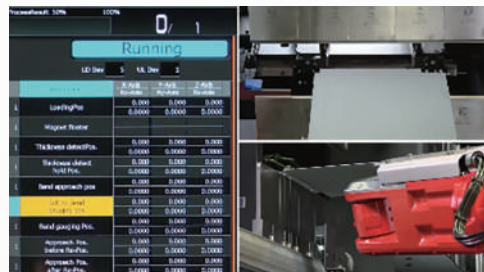

#### Z-direction sensing (height adjust sensor)

The laser displacement sensor automatically adjusts the height of the part position when initiating a new production run.

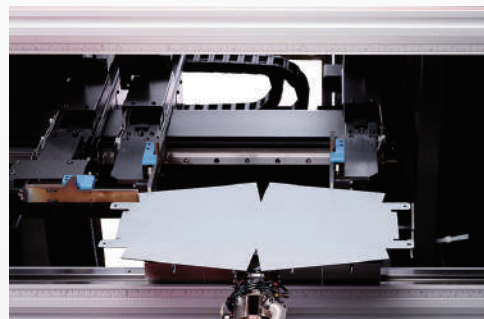

#### Side gauge & Back gauge sensor

Sensors in the side gauge and back gauge automatically correct the horizontal and vertical position of the part. The gauging movement is expanded, thereby broadening the range of applicable product shapes, including tapered bending.

### Programming

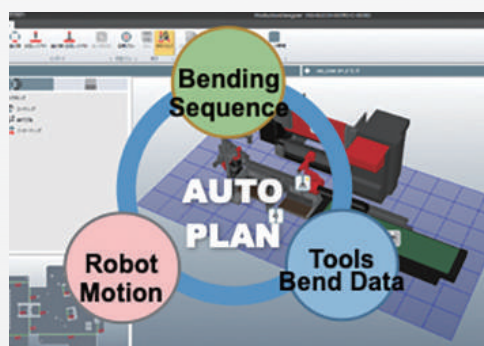

#### VPSS 4ie ARBEND (software)

Our Robot CAM software allows off-line programming without interrupting robot operation.



## Efficiency Can be used anywhere

Option

### Pallet operation



#### No reloading

Materials can be loaded onto pallets through external setup, eliminating the labor-intensive task of reloading work. The pallet can be positioned using a hand-lifter.



#### Expanded vertical loading operation range

If part blanks cannot be stacked, they must be loaded vertically. The maximum part size is now increased to 800 x 1000mm, compared to the former maximum size of 400 x 400mm. Additionally, pallet operations are available for vertical loading in external parts setup.

### Robot tablet HMI & FMS controller



#### Setup support

The portable robot tablet HMI can display setup information and CAM simulation.

\*iPad should be prepared by the customers

This enables the confirmation of essential information anywhere and anytime.

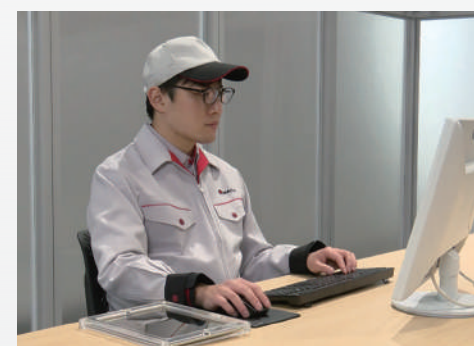

#### Schedule operation

The FMS controller allows the creation and editing of schedules even during operation, following the production plan. Contents in the FMS controller can be edited or confirmed using the Robot tablet HMI.

(FMS controller is under Software products)

\*Minimum flange length may differ depending on bending angles or shapes of die to be used.



## Environmental

Environmentally-friendly

### New servo drive

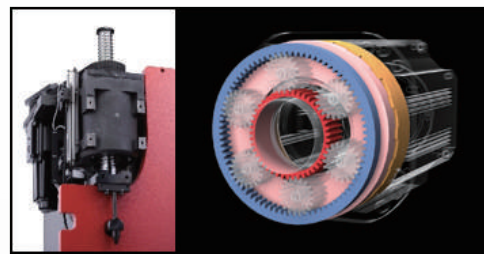

### High speed & High accuracy

Achieving high speed/low torque and low speed/high torque with a single motor.

Stable high accuracy is maintained, unaffected by temporal changes in oil temperature.

Max. approach speed 250mm/s

Max. bending speed 9mm/s (without robot motion)

Max. return speed 250mm/s



### Reduction of oil volume

Switching from the conventional hydraulic system to the servo motor system has drastically reduced the quantity of hydraulic oil, leading to decreased maintenance costs.



## Evolution

Growing Together with Our Customers

Option

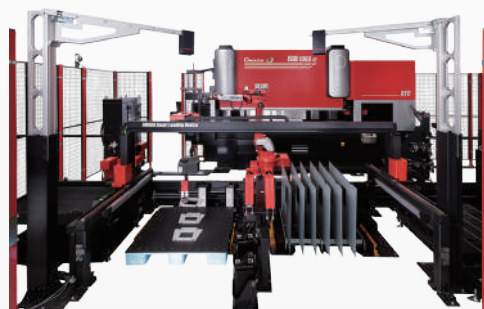

### AMADA smart loading device

The newly released AMADA Smart Loading Device for the EGB-1303ARse is an independent loading unit designed to efficiently supply pallet-loaded blanks to the bending robot. Compared with the conventional system where the robot picks up a blank, this reduces the dead zone area on the pallet, resulting in faster tact times.



### Sheet & Blank separation function

The EGB-1303ARse provides a diverse range of parts separation functions to prevent the picking up of multiple blanks.

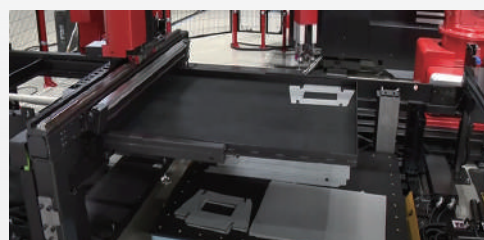

### Double pick-up tray

If multiple blanks are picked, automatic operation continues by placing the multiple blanks on a tray instead of halting the processing.

## Unloading Options



### Conveyor

For offloading of products which are small to medium in size.

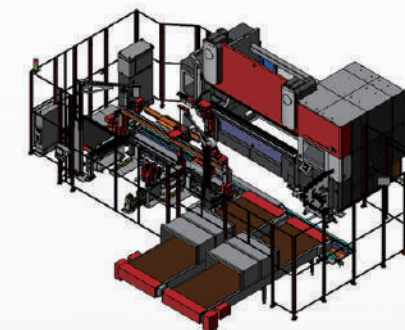

### Pallet changer + conveyor

For customers who want to use different unloading devices according to the size of products.

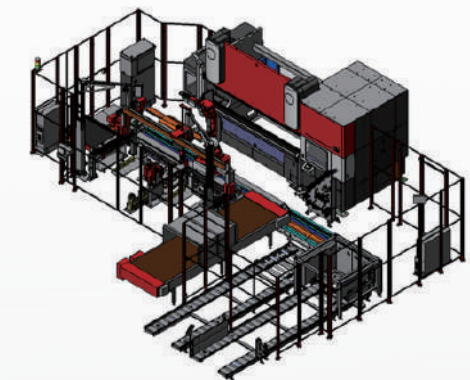

### Pallet changer 4 pcs. / 16 pcs.

For heavy, large, or panel-shaped products.

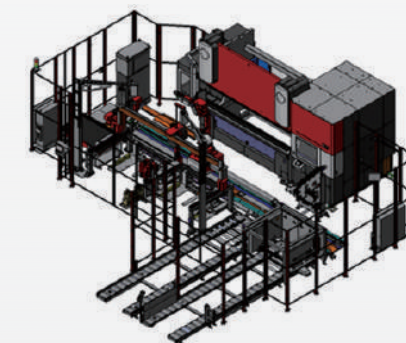

### Pallet

For heavy, large, or panel-shaped products.

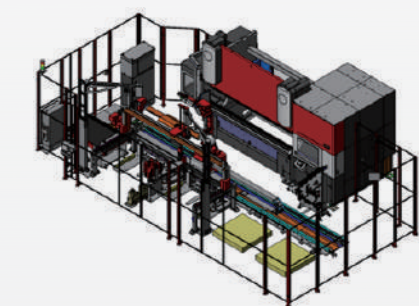

\*Layout images are subject to change without prior notice due to continuous improvement.  
\*Pallets shall be prepared by the customer.



### Other specifications

Option

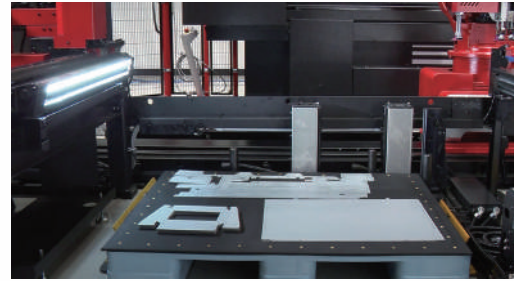

#### LD camera

A device utilizing image recognition to automatically detect the shape and position of blanks when the robot picks them up. The LD camera's ability to recognize the shape of blanks allows for loading of different blanks on a single pallet. This feature facilitates continuous operation and supports high-mix lowvolume production.

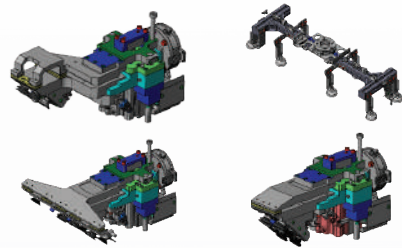

#### Various grippers (some are options)

Customers can choose from various types of grippers based on their products.

### Software

#### VPSS 4ie ARBEND

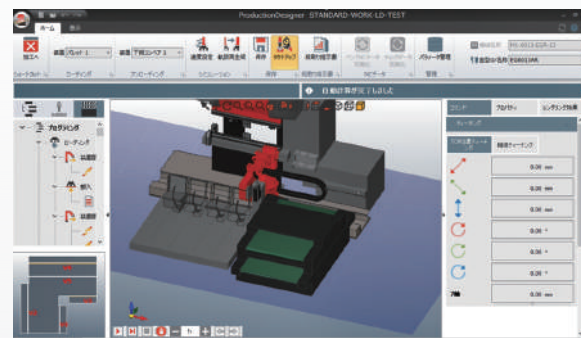

Equipped with the "Programming Assist" function, it generates programming for the bending robot by automatically calculating robot movements, bending steps, tool selections, etc. This enhancement significantly improves usability, making it easy to understand even for beginners, and reduces bending program creation time.

\*BEND CAM is necessary for ARBEND

### Bending robot LINE-UP

\*If the blank mass exceeds the robot's payload capacity, processing may not be possible even if it falls within the specified range.

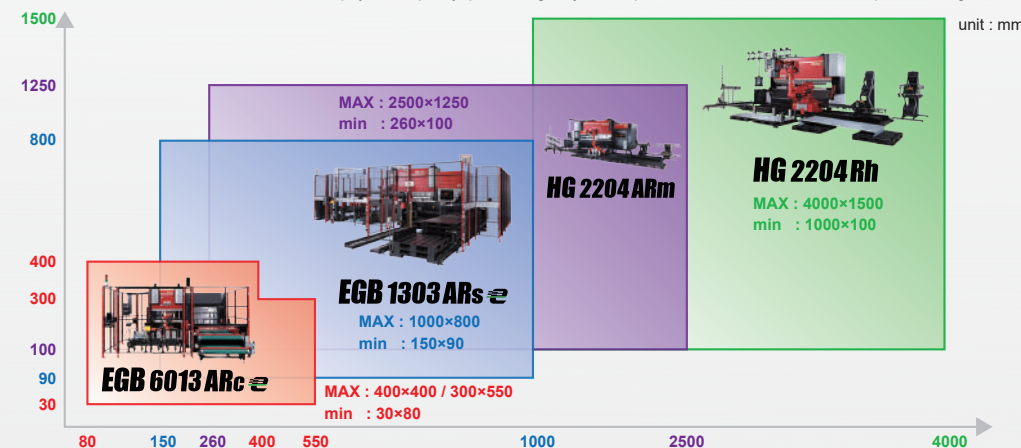

### V-factory

AMADA's recommended V-factory operates on the concept of "creating profits for customers." V-factory collaborates with customers to co-create factory reforms, utilizing IoT technology to visualize operations and maximize machine utilization.

#### V-factory Connecting Box

Used to connect machines to the cloud and the V-factory.

#### V-monitor \*

Automatically records the state of the machine during automatic operation.

